



**iMOW**  
by **EP EQUIPMENT**

**iMOW**  
by **EP EQUIPMENT**

# ICE301B/ICE351

Electric Counterbalance Forklift Truck 3.0/3.0T

- Lithium-ion technology
- Low TCO
- Easy driving
- Brilliant visibility
- Telematics

**iMOW**  
[www.imowshop.com](http://www.imowshop.com)



Scan and Enter iMOW Website

**NARA ENTERPRISE CO.,LTD**  
**HEAD OFFICE**

110/59 Pruksa Avenue Moo.4 Bangkaew, Bangphli, Samut Prakarn 10540  
Thailand

Tel : +662-007-6595

Hotline : +6692-445-4291/ +6683-666-4594

[www.naraenterprise.com](http://www.naraenterprise.com)      Email : [info@naraenterprise.com](mailto:info@naraenterprise.com)

**iMOW**

## PRODUCT FEATURES

### ■ Lithium-ion technology

ICE 301B/ICE 351 adapts LFP Li-ion battery that prevents the battery from self-ignition and ensures safety operation. ICE 301B/ICE 351 supports opportunity charging so it can be charged at preferable time during the day without disrupting working schedules.

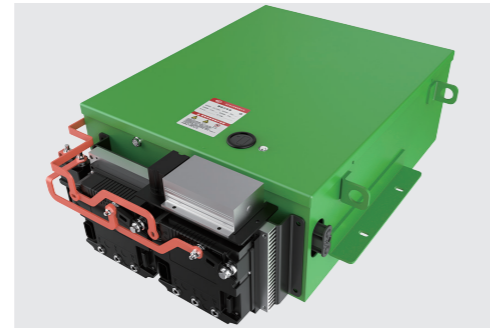

### ■ Low TCO

Comparing to a diesel forklift truck, ICE 301B/ICE 351 saves 30%-50% of energy cost with li-ion technology. And there is no maintenance fee with no air filter, oil filter, engine oil or starter battery installed on the truck.

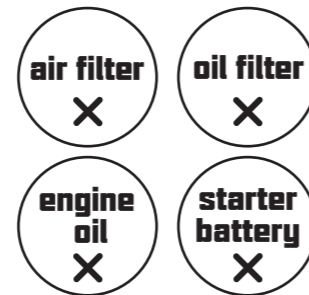

### ■ Easy driving

The truck is equipped with electric-hydraulic braking system. The system shortens the braking distance to ensure safety while reducing the driving fatigue in the mean-time.



### ■ Brilliant visibility

A wide view mast ensures good visibility during operation. This enables operator to better monitor the status of the cargo.



### ■ Telematics

ICE 301B/ICE 351 offers EP's latest Telematics. It provides the following features to facilitate your fleet management:

- Truck location in real-time
- Reports of truck usages and diagnosis
- Li-ion battery condition analytics
- Updates on card access registration



## PRODUCT PARAMETERS

Distinguishing mark				
1.1	Manufacturer			IMOW
1.2	Model designation			ICE301B
1.3	Drive unit			Electrics
1.4	Operator type			seated
1.5	rated capacity	Q	kg	3000
1.6	Load center distance	c	mm	500
1.8	Load distance, centre of drive axle to fork	x	mm	481
1.9	Wheelbase	y	mm	1750
Weight				
2.1	Service weight (include battery)		kg	4080
2.2	Axle loading, laden driving wheels /steering wheels		kg	6420/660
2.3	Axle loading, unladen driving wheels /steering wheels		kg	1740/2340
Types,Chassis				
3.1	Tyre type,driving wheels /steering wheels			pneumatic
3.2	Tyre size, driving wheels			28X9-15-14PR
3.3	Tyre size, steering wheels			6.50-10-10PR
3.5	Wheels, number driving/steering (x=drive wheels)		mm	2x/ 2
3.6	Tread, Driving wheels	b10	mm	1010
3.7	Tread, Steering wheels	b11	mm	980
Dimensions				
4.1	Tilt of mast/fork carriage forward/backward	$\alpha/ \beta$ (°)		6/ 10
4.2	Height, mast lowered	h1	mm	2070
4.3	Free lift (load backrest)	h2	mm	150
4.4	Lift height	h3	mm	3000
4.5	Height, mast extended	h4	mm	4050
4.7	Height of overhead guard (cabin)	h6	mm	2160
4.8	Seat height	h7	mm	1130
4.12	Tow center of pin height	h10	mm	320
4.19	Overall length	l1	mm	3780
4.20	Length to face of forks	l2	mm	2710
4.21	Overall width	b1/ b2	mm	1230
4.22	Fork dimensions	s/ e/ l	mm	45×125×1070
4.23	Fork carriage class/type A, B			3A
4.24	Fork carriage width	b3	mm	1150
4.31	Ground clearance, laden, below mast	m1	mm	120
4.32	The minimum ground clearance of frame	m2	mm	150
4.34.1	Aisle width for pallets 1000 × 1200 crossways	Ast	mm	4181
4.34.2	Aisle width for pallets 800 × 1200 lengthways	Ast	mm	4381
4.35	Turning radius	Wa	mm	2500
Performance data				
5.1	Travel speed, laden/ unladen		km/ h	11/12
5.2	Lifting speed, laden/ unladen		m/ s	0.29/0.36
5.3	Lowering speed, laden/ unladen		m/ s	0.4/0.43
5.8	Max. gradeability, laden/unladen		%	15/15
5.10	Service brake type			Hydraulic / Mechanical
	park brake type			Mechanical
Electric-engine				
6.1	Drive motor rating S2 60 min		kW	10
6.2	Lift motor rating at S3 15%		kW	12
6.3	The maximum allowed size battery		mm	731X 608X326
6.4	Battery voltage/nominal capacity K5			80V205AH
Addition data				
8.1	Type of drive unit			AC
10.5	Steering type			Hydraulic steering
10.7	Sound pressure level at the driver's ear		dB (A)	< 74

## RATED CAPACITY

RATED CAPACITIES AND LOAD CENTERES GRAPH

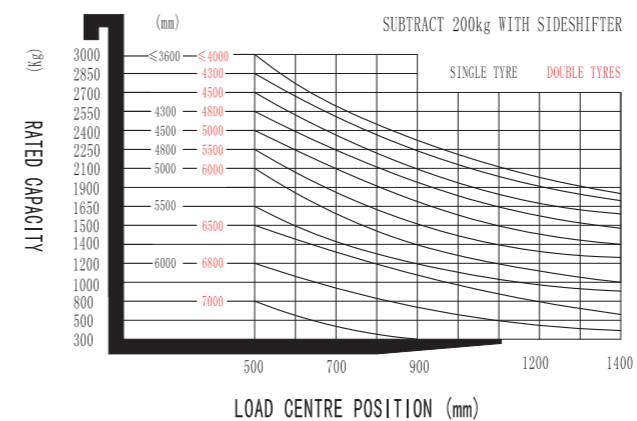

RATED CAPACITIES AND LOAD CENTERES GRAPH

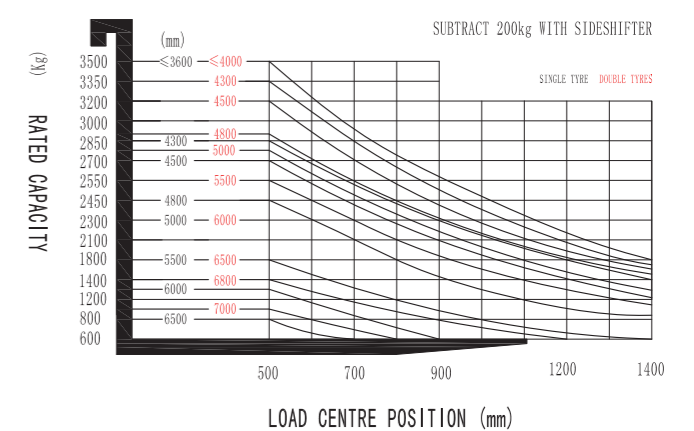

# MAST OPTION

Type	Model	Max. fork height	Overall height				Free lift		Front Overhang		Tilt range		Capacity	
			Lowered	Extended		Without backrest	With backrest	3.0t	3.5t	FWD	BWD	Load capacity at 500 mm		
				Without backrest	With backrest							Single tire	Double tire	
mm	mm	mm	mm	mm	mm	mm	mm	Deg	Deg	kg	kg			
Wide view mast	2W200	2000	1570	2570	3110	120	120	481	486	6	10	3000	3000	
	2W250	2500	1820	3070	3610	120	120	481	486	6	10	3000	3000	
	2W270	2700	1920	3270	3810	120	120	481	486	6	10	3000	3000	
	2W300	3000	2070	3570	4110	120	120	481	486	6	10	3000	3000	
	2W330	3300	2220	3690	4410	120	120	481	486	6	10	3000	3000	
	2W350	3500	2320	3890	4610	120	120	481	486	6	10	3000	3000	
	2W360	3600	2370	3990	4710	120	120	481	486	6	10	3000	3000	
	2W400	4000	2620	4040	5110	120	120	481	486	6	10	2850	3000	
	2W430	4300	2770	4340	5410	120	120	481	486	6	6	2700	2900	
2W450	4500	2870	4290	5610	120	120	481	486	6	6	2550	2850		
wide view full 2-stage mast	2F250	2500	1805	2220	3610	1210	560	481	486	6	10	3000	3000	
	2F270	2700	1905	2320	3810	1310	660	481	486	6	10	3000	3000	
	2F300	3000	2055	2620	4110	1460	810	481	486	6	10	3000	3000	
	2F330	3300	2205	3870	4410	1610	960	481	486	6	10	3000	3000	
	2F360	3600	2355	4020	4710	1760	1110	481	486	6	10	3000	3000	
	2F400	4000	2605	4420	5110	2060	1410	481	486	6	10	2850	3000	
wide view full 3-stage mast	3F430	4300	2095	4910	5410	1360	730	495	500	6	6	2550	2850	
	3F450	4500	2175	5070	5610	1460	810	495	500	6	6	2400	2700	
	3F480	4800	2280	5375	5910	1565	915	495	500	6	6	2250	2550	
	3F500	5000	2365	5570	6110	1610	960	495	500	3	6	1650	2250	
	3F550	5500	2615	6150	6610	1770	1120	495	500	3	3	1800	2250	
	3F600	6000	2865	6570	7110	2020	1370	495	500	3	3	1200	2100	

Type	Model	Max. fork height	Overall height				Free lift		Front Overhang		Tilt range		Capacity			
			Lowered	Extended		Without backrest	With backrest	3.0t	3.5t	FWD	BWD	Load capacity at 500 mm				
				Without backrest	With backrest							Single tire	Double tire	Single tire	Double tire	
mm	mm	mm	mm	mm	mm	mm	mm	Deg	Deg	kg	kg	kg	kg			
Wide view mast	2W200	2000	1570	2570	3110	120	120	481	486	6	10	3000	3000	3500	3500	
	2W250	2500	1820	3070	3610	120	120	481	486	6	10	3000	3000	3500	3500	
	2W270	2700	1920	3270	3810	120	120	481	486	6	10	3000	3000	3500	3500	
	2W300	3000	2070	3570	4110	120	120	481	486	6	10	3000	3000	3500	3500	
	2W330	3300	2220	3690	4410	120	120	481	486	6	10	3000	3000	3500	3500	
	2W350	3500	2320	3890	4610	120	120	481	486	6	10	3000	3000	3500	3500	
	2W360	3600	2370	3990	4710	120	120	481	486	6	10	3000	3000	3500	3500	
	2W400	4000	2620	4040	5110	120	120	481	486	6	10	2850	3000	3320	3500	
	2W430	4300	2770	4340	5410	120	120	481	486	6	6	2700	2900	2850	3350	
2W450	4500	2870	4290	5610	120	120	481	486	6	6	2550	2850	2600	3200		
wide view full 2-stage mast	2F250	2500	1805	2220	3610	1210	560	481	486	6	10	3000	3000	3500	3500	
	2F270	2700	1905	2320	3810	1310	660	481	486	6	10	3000	3000	3500	3500	
	2F300	3000	2055	2620	4110	1460	810	481	486	6	10	3000	3000	3500	3500	
	2F330	3300	2205	3870	4410	1610	960	481	486	6	10	3000	3000	3500	3500	
	2F360	3600	2355	4020	4710	1760	1110	481	486	6	10	3000	3000	3500	3500	
	2F400	4000	2605	4420	5110	2060	1410	481	486	6	10	2850	3000	2920	3500	
wide view full 3-stage mast	3F430	4300	2095	4910	5410	1360	730	495	500	6	6	2550	2850	2850	3350	
	3F450	4500	2175	5070	5610	1460	810	495	500	6	6	2400	2700	2700	3200	
	3F480	4800	2280	5375	5910	1565	915	495	500	6	6	2250	2550	2450	2900	
	3F500	5000	2365	5570	6110	1610	960	495	500	3	6	1650	2250	2300	2750	
	3F550	5500	2615	6150	6610	1770	1120	495	500	3	3	1800	2250	1800	2550	
	3F600	6000	2865	6570	7110	2020	1370	495	500	3	3	1200	2100	1300	2300	

# LINE GRAPH

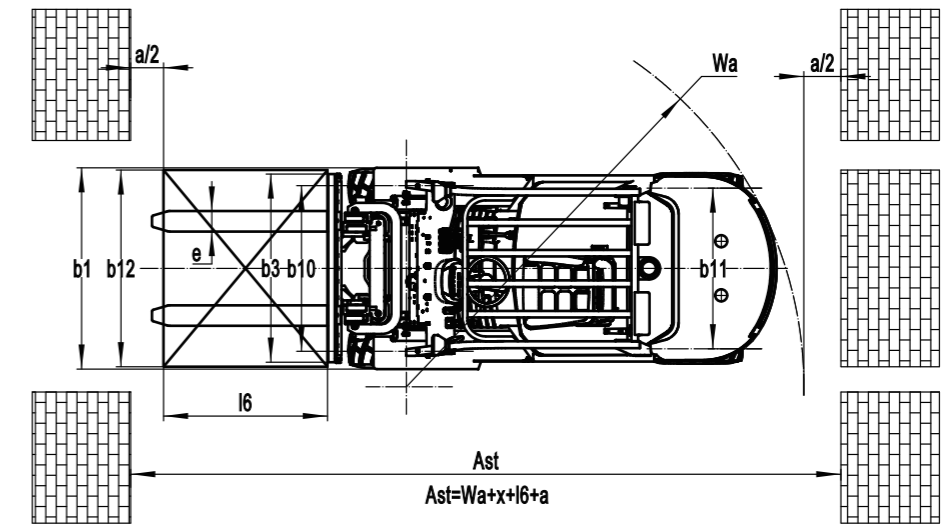
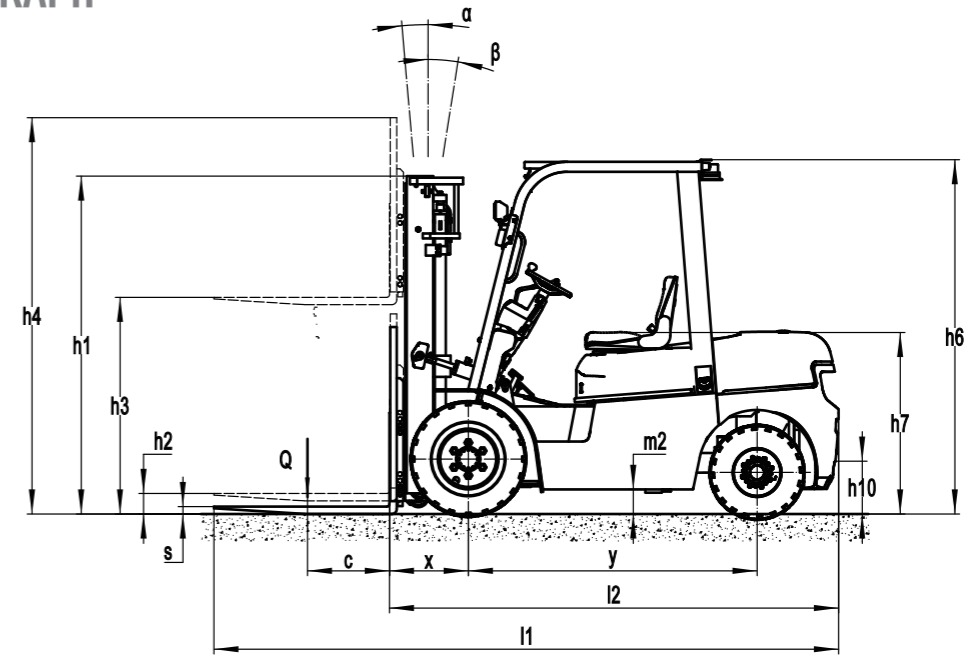

# OPTION

Optional items	ICE301B	ICE351
1 Fork length	●1070○customization consultation	●1070○customization consultation
2 Attachments	●NA○integrated side shifter○external side shifter ○ customization consultation	●NA○integrated side shifter○external side shifter ○ customization consultation
3 Overhead guard	●normal overhead guard ○customization consultation	●normal overhead guard ○customization consultation
4 Front wheel	●single○dual	●single○dual
5 Tyre type	●pneumatic○Solid rubber tire ○Environmental solid tire	●pneumatic○Solid rubber tire ○Environmental solid tire
6 Front light	●Front light	●Front light
7 Auxiliary light	●NA○Back light	●NA○Back light
8 Safety	●NA○Fire extinguisher○blue light	●NA○Fire extinguisher○blue light
9 Seat	●normal seat○suspension seat	●normal seat○suspension seat
10 Cockpit	●NA○Cockpit○With fan heater○With front windshield wiper○With rear windshield wiper	●NA○Cockpit○With fan heater○With front windshield wiper○With rear windshield wiper
11 Rearview	●single○dual	●single○dual
12 Air fan	●NA○single	●NA○single
13 Charging	●80V65A○80V100A	●80V65A○80V100A
14 Li-Ion battery	-	-

Note: ● standard ○ option — NA